

SLT 270



FROZEN STONE



NUOVE TECNOLOGIE DEL FREDDO

Self-contained ice maker up to 150 kg - Pebble system

• Position n°



• Application fields

Hotel	●●●●●●●●●●	Fish market	●●●●●●●●●●
Restaurant	●●●●●●●●●●	Supermarket	●●●●●●●●●●
Fast food	●●●●●●●●●●	SPA	●●●●●●●●●●
Bar	●●●●●●●●●●	Medical	●●●●●●●●●●
Disco	●●●●●●●●●●	Industry	●●●●●●●●●●

• Features & Plus

- Compact and longlasting nuggets
- Low consumption (1 liter water / 1 kg ice) - aircooled vers.
- Electromechanical functioning
- External structure AISI 304 Scotch Brite
- Evaporator AISI 304, auger AISI 303 made
- Air Cooling and Water Cooling systems
- Standard and special voltages
- Insulated retractable door
- ON-OFF switch
- Dust proof water basin
- Easy cleaning thanks to rounded surfaces
- External protective filter, removable, easy to clean
- Internal bin insulation HCFC free
- Conformity to RoHS directive
- Automatic water charge
- Model in Tropical Class + 43 ° C
- Undercounter model

• Available pebble size

Drawing for reference only

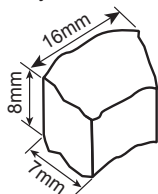

• Prod. 24h

Air temp.	Water temp.	Prod. 24h kg
10° C	10° C	150
21° C	15° C	140
32° C	21° C	126

2 Years Warranty

subject to limitations

• Certifications available for this model



N.T.F. S.r.l. Nuove Tecnologie del Freddo

Via dell'Industria 10/B tel. +39 0331 436217
20020 Villa Cortese (MI), Italy fax +39 0331 436218

www.ntfice.it
info@ntfice.it



ntfice.it



SLT 270



FROZEN STONE



Self-contained ice maker up to 150 kg - Pebble system

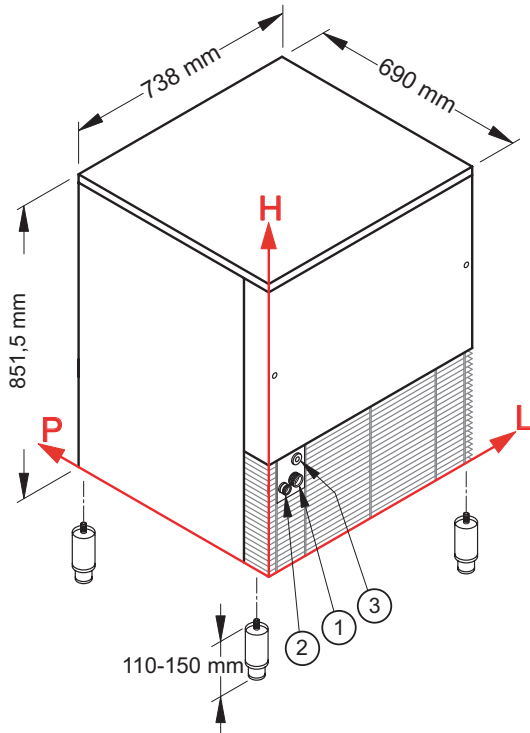

• Connections

All measures are referred to the rear bottom-left corner (L-H-Ø)

- ① Water inlet:
104 mm - 182 mm - 3/4"
- ② Water outlet:
53 mm - 175 mm - 24 mm
- ③ Electrical connection:
92 mm - 254 mm

• Working conditions

- Location: Indoor

	Min	Max
Ambient temperature	+10° C	+43° C
Water temperature	+3° C	+32° C
Voltage	-10%	+10%
Water inlet pressure	1bar (14 psi)	6bar (84 psi)

• Technical information

Production in 24h	140 kg
Store capacity, up to	40 kg
Cooling system	A - W
Approximate pebble size	8 x 16 x 7
Refrigerant	R404A
Standard voltage	220-240 V ~ 50 Hz
Electrical consumption	650 W
Fuse	10 A
Water consumption	A: 1 l/kg W: 6,4 l/kg
Sizes (L-P-H mm)	738 - 690 - 851,5
Sizes with pack (L-P-H mm)	780 - 735 - 1015
Net weight	90 kg
Gross weight	100 kg
Finish	AISI 304 stainless steel, scotch brite

All the technical information must be considered at the following conditions:

Sizes without feet	Ambient temperature +21° C	Water temperature +15° C	Electrical consumption at +43° C (standard voltage)

Models and specifications are subject to change without notice
Rev. 00 - Issued September 2016



N.T.F. S.r.l. Nuove Tecnologie del Freddo

Via dell'Industria 10/B
20020 Villa Cortese (MI), Italy

tel. +39 0331 436217
fax +39 0331 436218

www.ntfice.it
info@ntfice.it



ntfice.it

