

Split
3300 CO₂



FROZEN ICE



Modular ice maker 1520 kg - Scale system

● Position n°



● Application fields

Hotel	●●●●●●●●	Fish market	●●●●●●●●
Restaurant	●●●●●●●●	Supermarket	●●●●●●●●
Fast food	●●●●●●●●	SPA	●●●●●●●●
Bar	●●●●●●●●	Medical	●●●●●●●●
Disco	●●●●●●●●	Industry	●●●●●●●●

● Features & Plus

- Subcooled flakes (from -5°C to -10°C)
- 1 m³ = 430 kg of ice
- Low consumption (1 liter water / 1 kg ice)
- AISI 304 SS Scotch Brite finish
- Evaporator anticorrosive alloy made, with rotating knife
- Cleanable antiscaling filter
- Easy cleaning thanks to rounded surfaces
- FDA approved -ABS plastic components
- Conformity to RoHS directive
- Automatic water charge
- Standard and special voltages
- Model in Tropical Class + 43 ° C
- Pressure limiting valve, PS up to 40 bar

● Usable Bins

- Bin 1200DD
- DRB 1100
- DRB 2500

2 Years
Warranty

subject to limitations

● Certifications available for this model



N.T.F. S.r.l. Nuove Tecnologie del Freddo

Via dell'Industria 10/B,
20020 Villa Cortese (MI), Italy

tel. +39 0331 436217
fax +39 0331 436218

www.ntfice.it
info@ntfice.it



ntfice.it



**Split
3300 CO₂**



FROZEN ICE



Modular ice maker 1520 kg - Scale system

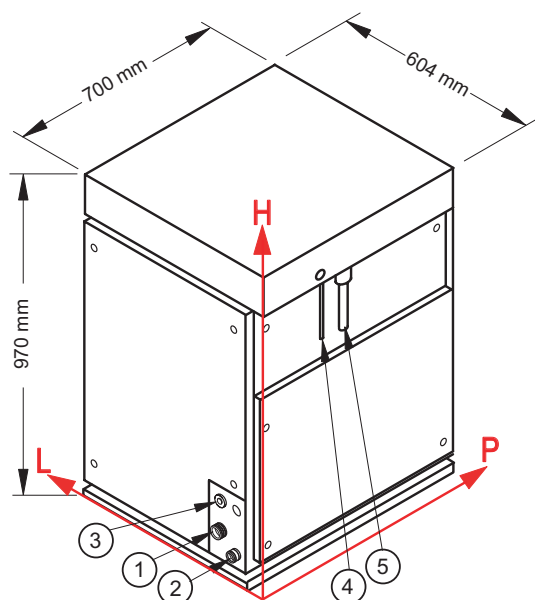

● Working conditions

- Location: Indoor

	Min	Max
Ambient temperature	+10° C	+43° C
Water temperature	+3° C	+32° C
Voltage	-10%	+10%
Water inlet pressure	1bar (14 psi)	6bar (84 psi)

● Technical information

Production in 24h	1520 kg
Refrigerant	CO ₂ (R744)
Refrigerant capacity	8550 W (evap. temp. -23° C)
PS suction side	580 PSI - 40bar
Standard voltage	220-240 V ~ 50 Hz
Electrical consumption	180 W
Sizes (L-P-H mm)	604 - 700 - 970
Sizes with pack (L-P-H mm)	655 - 785 - 1145
Net weight	144 kg
Gross weight	160 kg
Finish	AISI 304 stainless steel, scotch brite

● Connections

All measures are referred to the rear bottom-left corner (L-H-Ø)

- ① Water inlet:
123 mm - 120 mm - 3/4"
- ② Water outlet:
78 mm - 65 mm - 24 mm
- ③ Electrical connection:
123 mm - 204 mm
- ④ Refrigerant feeding pipe
- ⑤ Outlet pipe of gaseous refrigerant

All the technical information must be considered at the following conditions:



Refrigerant
capacity
8550 W
(evap. temp.
-23° C)



Water
temperature
+15° C



Electrical
consumption
at +43° C
(standard
voltage)

Models and specifications are subject to change without notice
Rev. 00 - Issued September 2016



N.T.F. S.r.l. Nuove Tecnologie del Freddo

Via dell'Industria 10/B, tel. +39 0331 436217
20020 Villa Cortese (MI), Italy fax +39 0331 436218

www.ntfice.it
info@ntfice.it



ntfice.it

